

Damping Pad

For Stacks

What is a damping pad?

A damping pad is a preformed **laminated fabric pad** of manufactured material composed of layers of tightly twisted, closely woven lightweight material. Each layer is made up of an elastomeric compound containing **mold and mildew** inhibiting agents.

What is it used for?

Because steel stacks have relatively **low inherent** structural damping, excessive top-of-stack deflection can result at critical wind speeds due to vortex shedding. To keep these deflections within acceptable limits, a damping pad is placed **between** the stack base plate and concrete foundation and conforms to the exact shape and size of the base plate.

The addition of the damping pad **increases** the inherent structural damping in the stack and foundation system, **reducing** deflection due to vortex shedding.

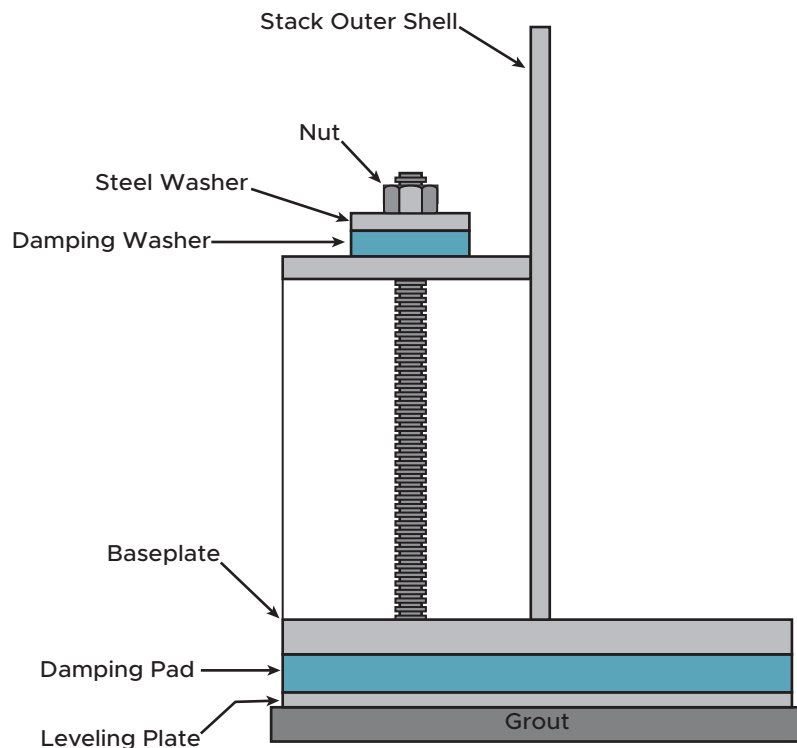

Advantages

1. Does **not** increase wind loads
2. **Compressive** strength 12,000 psi [82.7 MPa]
3. Impervious to most **oils and solvents**
4. **Resist** effects of steam, water, mildew and brine
5. Temperature range: **-40 °F [-40 °C] to 200 °F [93 °C]**

Disadvantages

1. Only withstand temperatures up to **200 °F [93 °C]**
2. Not always attractive to **retrofit existing** stacks
 - Requires extra **projection** of anchor bolts
 - Must **lift** stack for installation
3. Slight increase in **lateral deflection**

How do damping pads work?

A stack foundation can be **very rigid** and offer little inherent structural damping. A damping pad is **not as stiff** as steel and concrete. Adding a damping pad **increases** the structural damping of the system and **reduces** the vibration amplitudes that occur due to resonant structural vibration.

How Much Damping Can Be Achieved?

Damping can **vary greatly**. We recommend **sending** us your MecaStack input file and we can give you an **estimate** based upon your specific situation. If that is not feasible, a conservative estimate is to use a structural damping of **0.003**.

Will This Cause the Stack to See Larger Lateral Deflections Due to Along Wind Loads?

The damping pads do introduce some elasticity into the base, but they are also very stiff. There will be **minimal** impact on the lateral deflection due to along wind loads.

Do the Pads Hold up Over Time?

These pads have been in service for up to 30 years, with no reported problems.

Can Pads be Used on Existing Stacks?

It is possible to use pads on existing stacks, but the stack must be **raised** in order to insert a pad under the baseplate. Typically pads are **1 in [25.4 mm]** thick, so it must also be considered that stack connections will be raised approximately **1 in [25.4 mm]**. Typically a damping pad is **not used** to retrofit an existing stack because there are generally better options available for this situation.